

INSTRUKCJA OBSŁUGI

Rekuperatory decentralne WTW-WAND-WI-150- 60

USER MANUAL

Decentralized heat recovery units WTW-WAND-WI-150-60



Instrukcja obsługi / User Manual

Spis treści / Contents

1. General information	10
1.1 Description of the unit	10
1.2 How to use this manual	10
1.3 Admonitions	10
2. Safety	10
2.1 General safety instructions	10
2.2 Precautions for installation, use and maintenance	10
2.3 Directives / Norms	11
3. Technical data	11
3.1 Features	11
3.2 Technical specification	12
3.3 Dimensions (mm)	12
4. Operation	13
4.1 Description of the unit operation	13
4.2 Optional accessories (sold separately)	14
5. Synchronisation	14
5.1 Synchronisation of few units	14
5.2 Reset of the synchronisation	14
6. Jumper positioning	14
7. Maintenance and service	14
8. Disposal and recycling	15
9. Installation	16
10. Reset of the synchronization	21
11. Filter cleaning (maintenance)	22
12. Heat exchanger cleaning (service)	23
13. Energy Label	25
14. Product fiche according to ERP Directive, Regulations 1253/2014, 1254/2014	27

User Manual

WTW-WAND-WI

1. General information

1.1 Description of the unit

WTW-WAND is a single alternate flow decentralized (single point) residential heat recovery unit, also called «push&pull» unit, designed to ensure adequate ventilation in enclosed environments without energy losses. It is recommended that two units are installed in pair: when one unit is pulling, the other is pushing. Pair of units can be installed in the same room or in different rooms (i.e. livingroom and bedroom). The unit is suitable for installation on an outside WAND.



The unit should operate continuously, and only stopped for maintenance or service. When heat exchange is not useful (for example in mid-seasons when indoor and outdoor temperatures are similar), or when heat exchange is not recommended (for example with the option "summer free cooling"), it is recommended to set the unit in "extract-only" or "intake-only" mode and NOT to switch it off.

1.2 How to use this manual

Read this manual carefully before using the product and keep it in a safe place for reference.

1.3 Admonitions



WARNING identifies a hazard that could lead to personal injury, including death



NOTE is used to highlight additional information.

2. Safety

2.1 General safety instructions

This product was constructed up to standard and in compliance with regulations relating to electrical equipment and must be installed by technically qualified personnel. The manufacturer assumes no responsibility for damage to persons or property resulting from failure to observe the regulations contained in this manual.

2.2 Precautions for installation, use and maintenance

- The device should not be used for applications other than those specified in this manual.
- After removing the product from its packaging, verify its condition. In case of doubt, contact a qualified technician. Do not leave packaging within the reach of small children or people with disabilities.
- Do not touch the appliance with wet or damp hands/feet.
- This appliance can be used by children aged from 8 years and above and persons with reduced physical, sensory or mental capabilities or lack of experience and knowledge if they have been given supervision or instruction concerning use of the appliance in a safe way and understand the hazards involved. Children shall not play with the appliance. Cleaning and user maintenance shall not be made by children without supervision.
- Do not use the product in the presence of inflammable vapours, such as alcohol, insecticides, gasoline, etc.

User Manual

WTW-WAND-WI

- If any abnormalities in operation are detected, disconnect the device from the mains supply and contact a qualified technician immediately. Use original spare parts only for repairs.
- The electrical system to which the device is connected must comply with regulations.
- Before connecting the product to the power supply or the power outlet, ensure that: the data plate (voltage and frequency) correspond to those of the electrical mains and the electrical power supply/socket is adequate for maximum device power. If not, contact a qualified technician.
- The device should not be used as an activator for water heaters, stoves, etc., nor should it discharge into hot air/fume vent ducts deriving from any type of combustion unit. It must expel air outside via its own special duct.
- Operating temperature: -20°C up to +50°C.
- The device is designed to extract clean air only, i.e. without grease, soot, chemical or corrosive agents, or flammable or explosive mixtures.
- Do not leave the device exposed to atmospheric agents (rain, sun, snow, etc.).
- Do not immerse the device or its parts in water or other liquids.
- Turn off the main switch whenever a malfunction is detected or when cleaning.
- For installation an omnipolar switch should be incorporated in the fixed wiring, in accordance with the wiring regulations, to provide a full disconnection under overvoltage category III conditions (contact opening distance equal to or greater than 3mm).
- If the supply cord is damaged, it must be replaced by the manufacturer, its service agent or similarly qualified persons in order to avoid a hazard.
- Do not obstruct the fan or exhaust grille to ensure optimum air passage.
- Ensure adequate air return/discharge into/from the room in compliance with existing regulations in order to ensure proper device operation.
- If the environment in which the product is installed also houses a fuel-operating device (water heater, methane stove etc., that is not a "sealed chamber" type), it is essential to ensure adequate air intake, to ensure good combustion and proper equipment operation.

2.2 Directives / Norms

- 2014/35/EU Low Voltage Directive (LVD) and 2014/30/EU Electromagnetic Compatibility (EMC), in conformity with the following standards:
- Electrical Safety: EN60335-1(2012)+A11+A13; EN 60335-2-80(2003) +A1+A2.
- Electromagnetic Compatibility: EN 55014-1(2017); EN 55014-2 (2015); EN 61000-3-2(2014); EN 61000-3-3(2013).

3. Technical data

3.1 Features

- Tube material: high quality, impact and UV-resistant ABS colour RAL 9010.
- Design front cover removable for cleaning without the use of tools.
- Easy maintenance installation plate, for easy access to the heat exchanger from inside the room.
- Anti-dust filter, easily removable for washing by the user without tools.
- Regenerative honeycombs ceramic heat exchanger.
- External grille in high quality, external hood in aluminium, painted in white RAL 9010, acoustically lined.
- High efficiency aerodynamic fan with "winglet" blades to optimise quietness and efficiency.
- Single phase EC reversible brushless motor with integral thermal protection.
- Motor mounted on high quality ball bearings.
- The unit is double insulated: no earth connection is required.
- Trickle speed selectable.
- Boost mode.
- Free-cooling (Bypass single direction) mode.

User Manual

WTW-WAND-WI

- IPX4 degree of protection.
- Power supply 220V to 240V~ 50Hz.

3.2 Technical specification

Model	Airflow [m ³ /h]	Power [W]	Weight [kg]
WTW-WAND-100-25	10/15/25	1.2/1.7/2.6	2.4
WTW-WAND-150-60	20/40/60	1.4/2.3/3.8	4.3

3.3 Dimensions (mm)

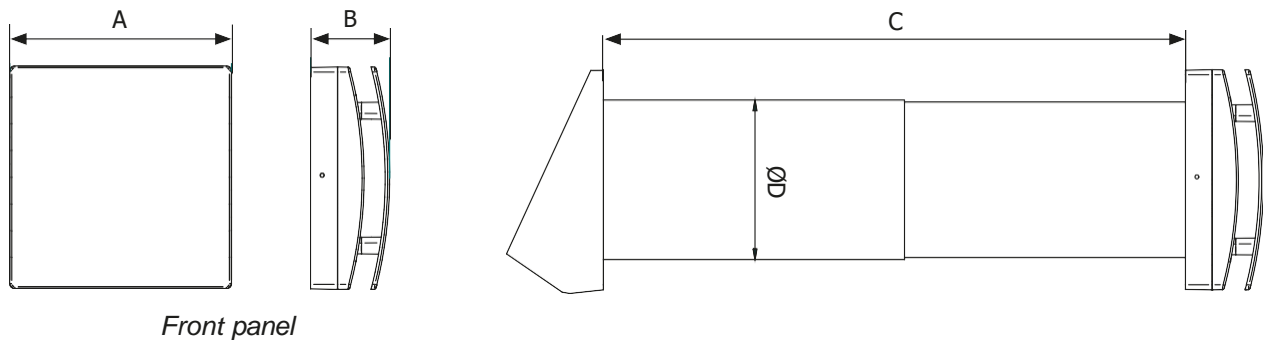

Front panel

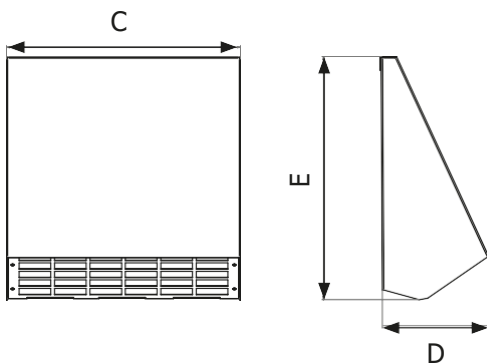

External hood

	WTW-WAND-100-25	WTW-WAND-150-60
Dimension A	164	218
Dimension B	46	51
Dimension C	205	252
Dimension D	103	114
Dimension E	209	262
Dimension F	270÷510	300÷560
Dimension G	100	150

User Manual

WTW-WAND-WI

4. Operation

4.1 The installation of the app and pairing of the device

Step 1.

Download the HAQCS Remote application from the Google Play or App Store and install it on your Android or iOS device. An app installed on the smartphone allows you to control a single heat recovery unit or a group of heat recovery units within range of the WLAN (Wi-Fi network) (Wi-Fi network).



Step 2.

Make sure all devices are within the router's range.

Set the jumper in the App position.

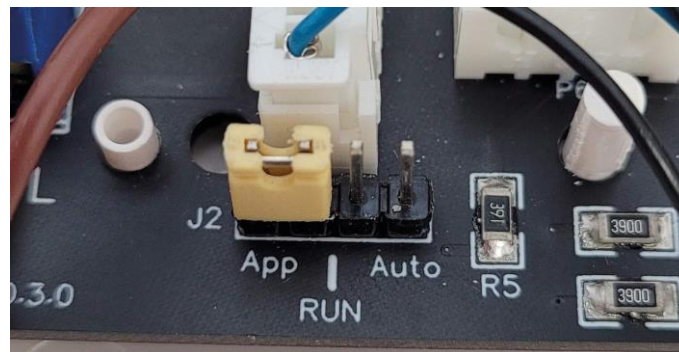

Step 3.

When the heat recovery unit is turned on, it creates a Wi-Fi access point called WTW-WAND-150 which does not require a password. Connect the smartphone to this access point. Next, run the application and go to „Settings“.

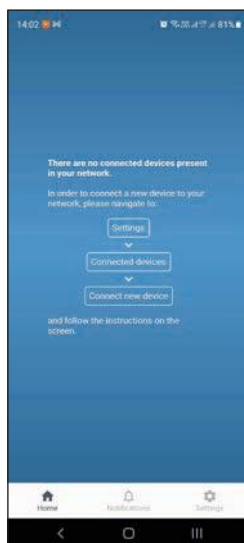

User Manual

WTW-WAND-WI

Step 4.

Then select „Connect a new device“.



Step 5.

Select your Wi-Fi network and enter the password (to which the WTW-WAND-WI and smartphone / tablet will be connected).

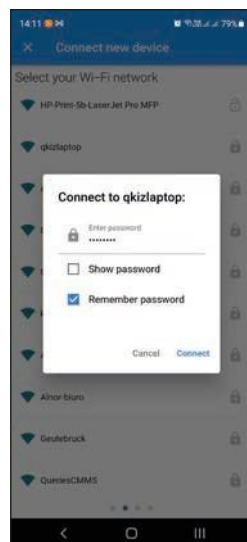

After logging in to the network, the device turns off its WTW-WAND-150 access point.



User Manual

WTW-WAND-WI

Step 6.

Your smartphone should be reconnected to your Wi-Fi network. If this condition is met, the application will proceed to the next screen.

Step 7.

Select the room in which the device is installed. You can also add a new group.

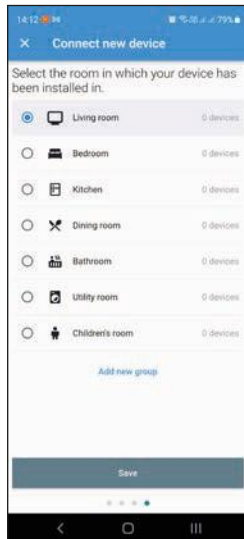

Step 8.

Turn off the power to the heat recovery unit and set the jumper to **RUN** mode.

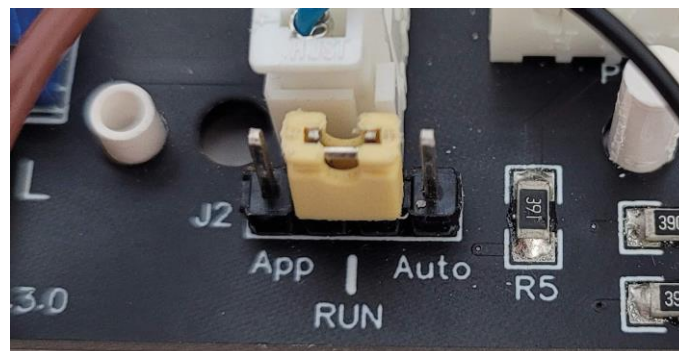

Step 9.

It is necessary to repeat the above steps for all WTW-WAND-WI-150-60 units.

User Manual

WTW-WAND-WI

5. Synchronisation

5.1 Synchronisation of few units

When the units are installed in pair, they must be synchronised so that when one unit is extracting, the other is supplying, and viceversa.

This is achieved by setting the dedicated jumper (Fig. 20A-20B). One unit is set in A position, other in B position. Units which are supposed to work in synchronisation mode can be connected to a single WTW-WAND- CONTR / WTW-WAND-CONTR-I controller. One can connect up to 10 units to a single controller.

5.2 Reset of the synchronisation

OPTION 1: If two or more units are connected under the same main switch, to reset the synchronisation, the main switch must be switched first OFF and then ON to reactivate (Fig. 34).

OPTION 2: If two or more units are not connected under the same main switch, to reset the synchronisation, press at the same time the black pin of each unit (Fig. 36) for at least 3 seconds.

6. Jumper positioning

Integral jumper set in position A (Fig. 20A) means "extract-only" mode.

Integral jumper set in position B (Fig. 20B) means "supply-only" mode.

The jumper position defines both the air-flow direction when the unit is activated for the first time (for the synchronisation) and the air-flow direction of the free-cooling mode.

7. Maintenance and service

Maintenance can be carried out by the user as indicated at page 22.

Service must be performed only by technically qualified personnel in accordance with local rules and regulations. Make sure that the mains supply to the unit is disconnected (page 23).

Cleaning of the heat exchanger can be performed from outside as well.

8. Disposal and recycling

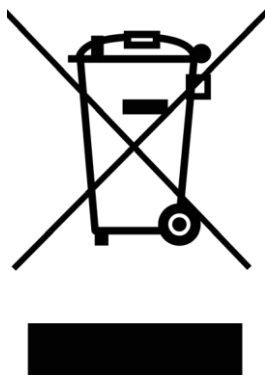

Information on disposal of units at the end of life. This product complies with EU Directive 2002/96/EC. The symbol of the crossed-out dustbin indicates that this product must be collected separately from other waste at the end of its life. The user must, therefore, dispose of the product in question at suitable electronic and electro-technical waste disposal collection centres, or else send the product back to the retailer when purchasing a new, equivalent type device.

Separate collection of decommissioned equipment for recycling, treatment and environmentally compatible disposal helps to prevent negative effects on the environment and on health and promotes the recycling of the materials that make up the equipment.

Improper disposal of the product by the user may result in administrative sanctions as provided by law.

Instrukcja obsługi

WTW-WAND-WI

9. Montaż / Installation

Zawartość opakowania/ Package contents

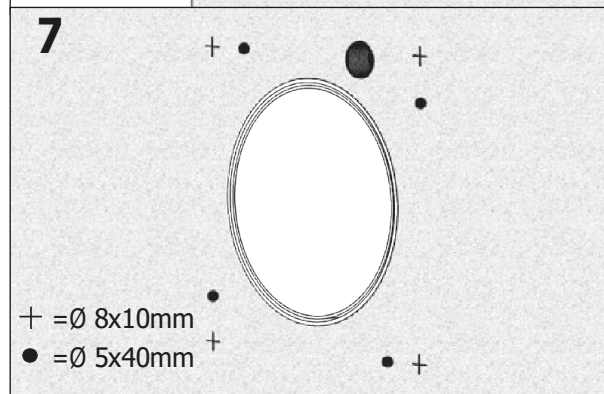
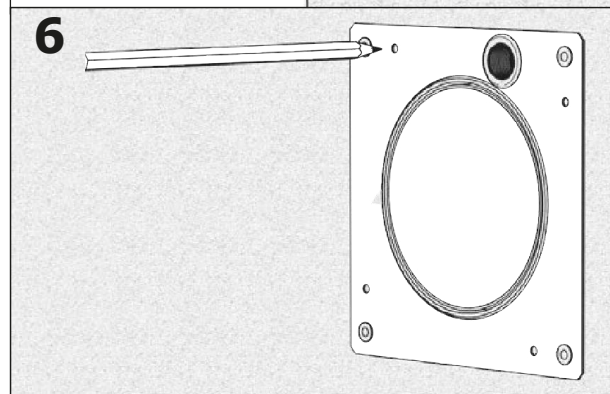
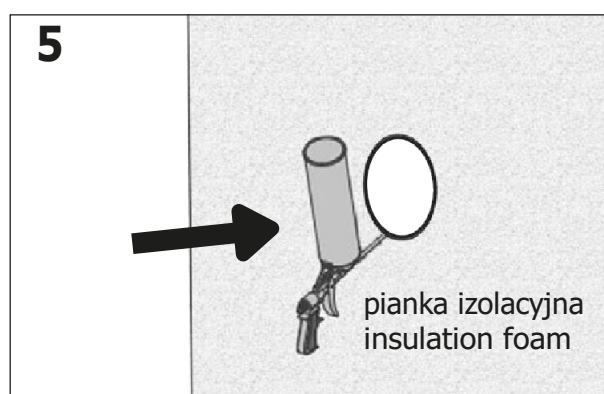
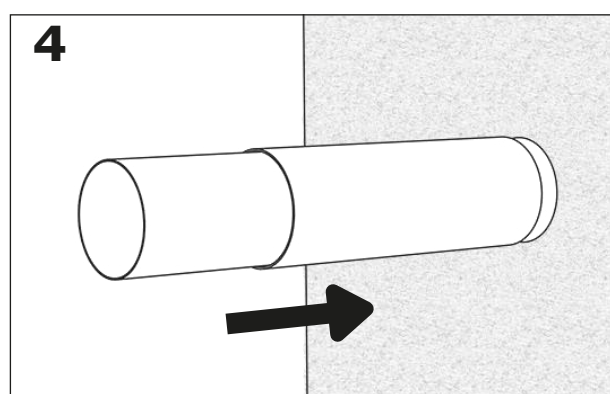
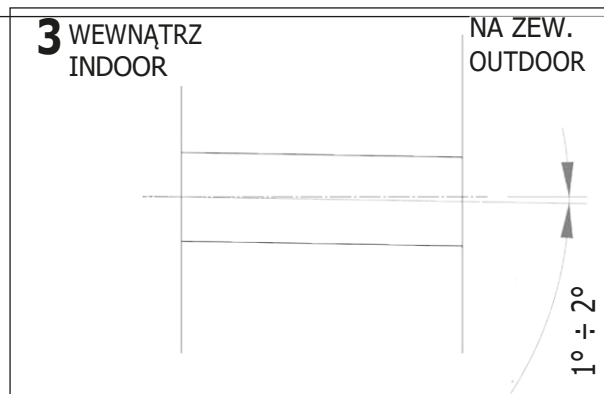
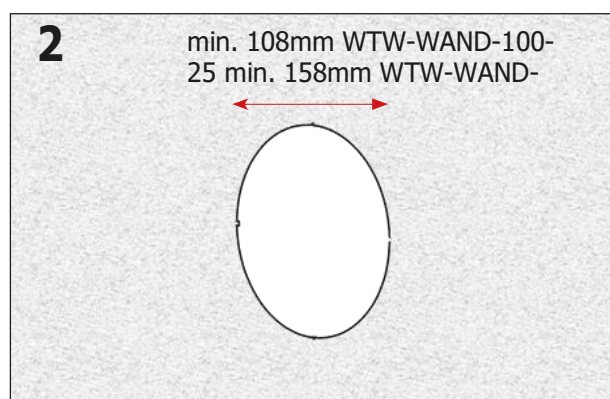
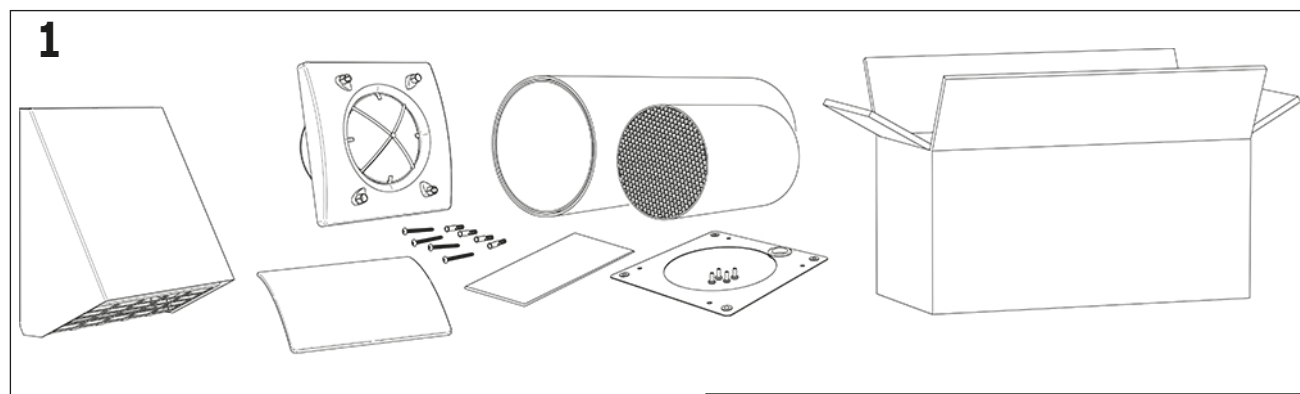

Instructie obsługi

WTW-WAND-WI

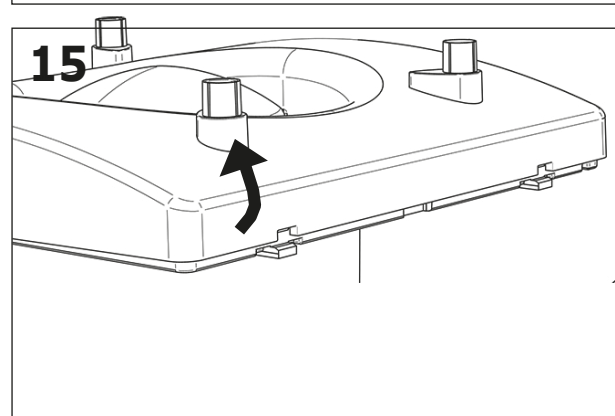
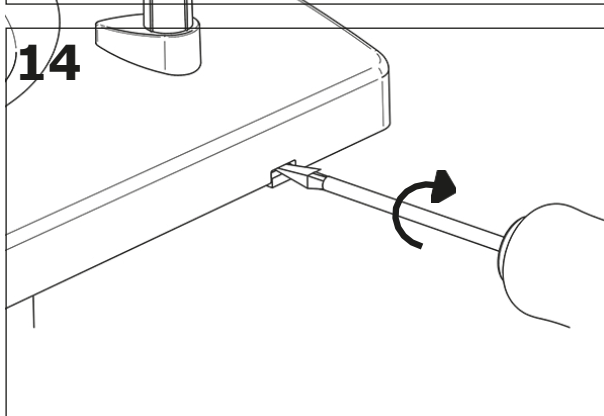
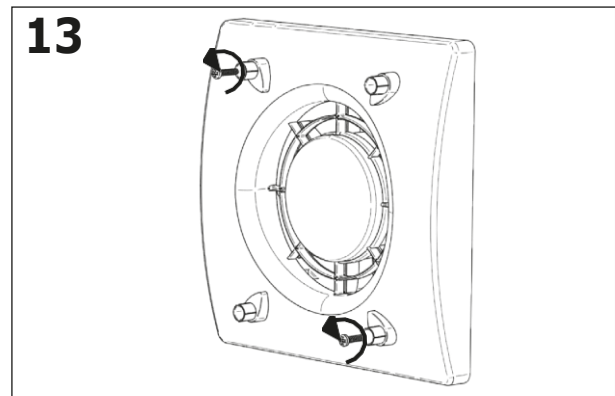
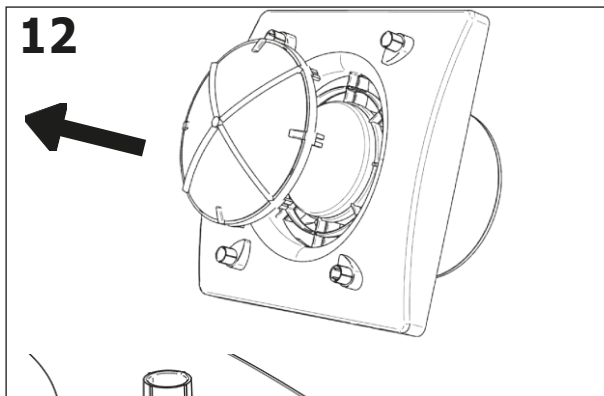
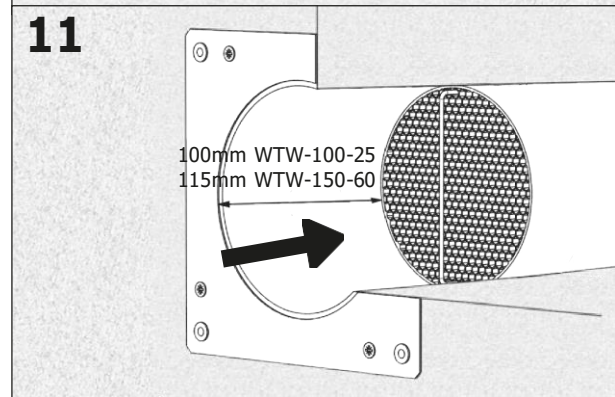
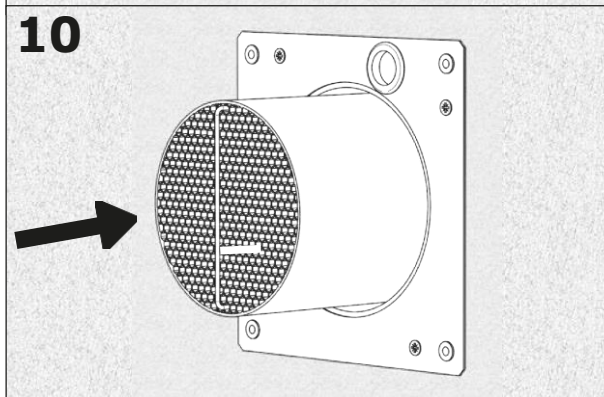
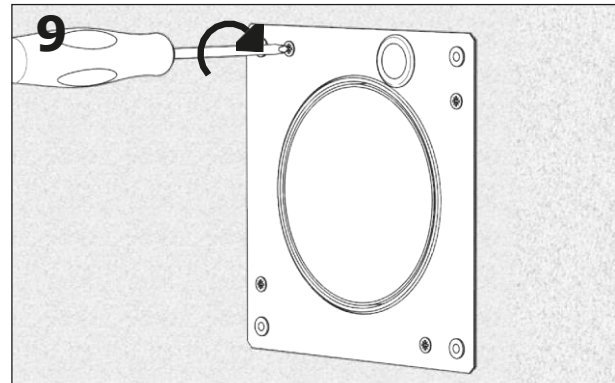
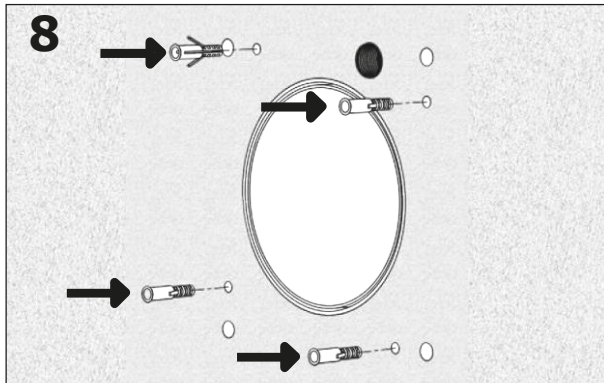

Instrukcja obsługi

WTW-WAND-WI

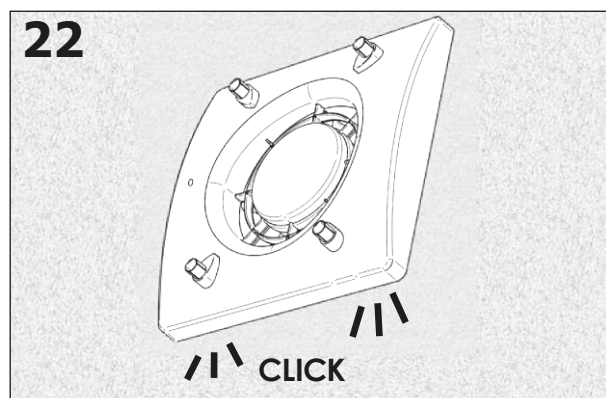
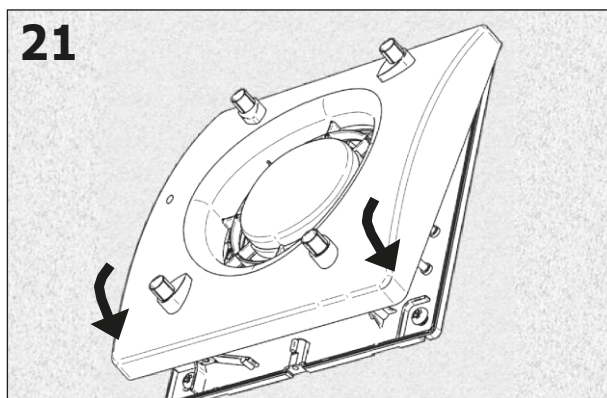
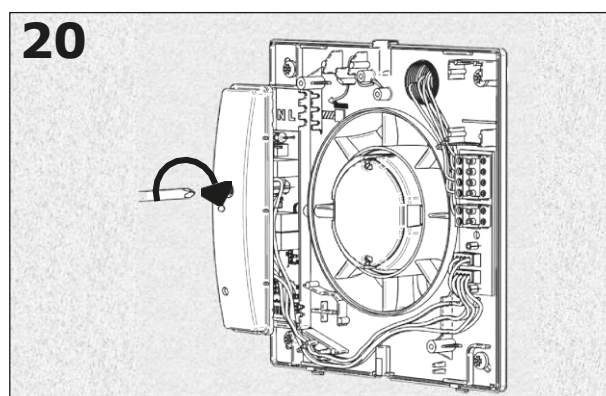
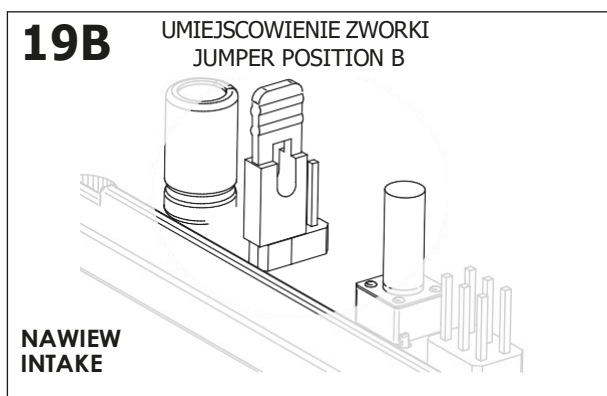
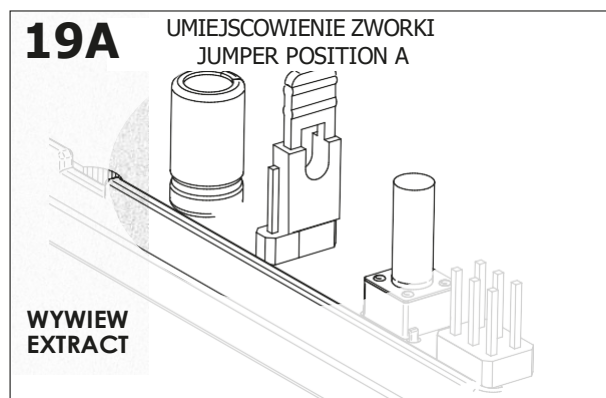
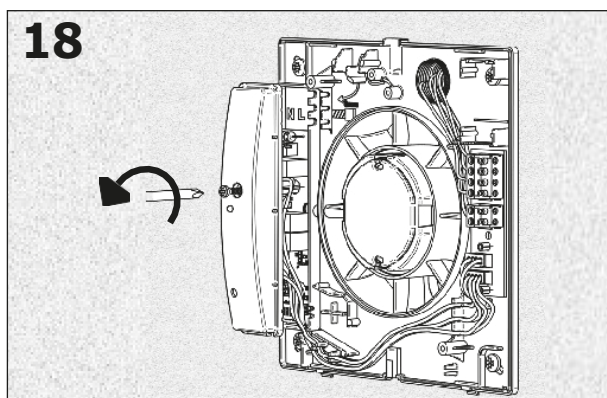
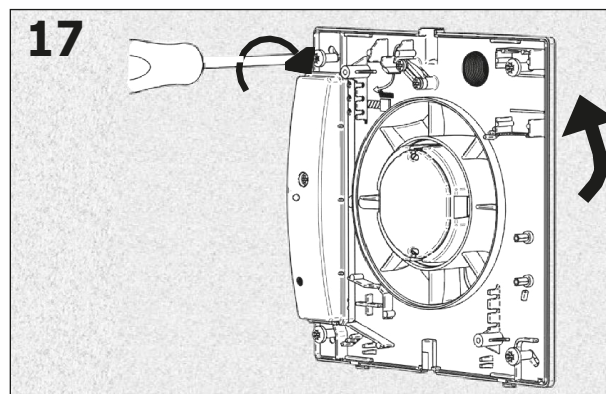
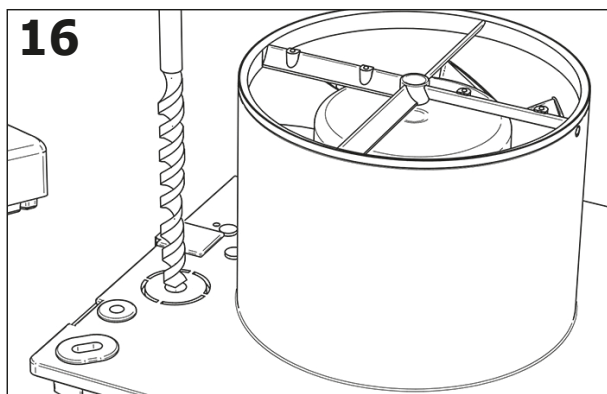

Instructie obsługi

WTW-WAND-WI

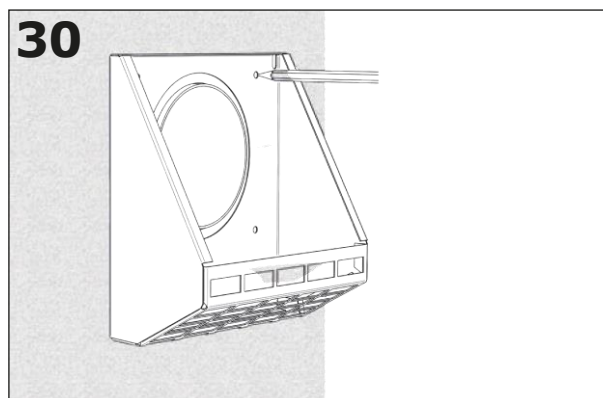
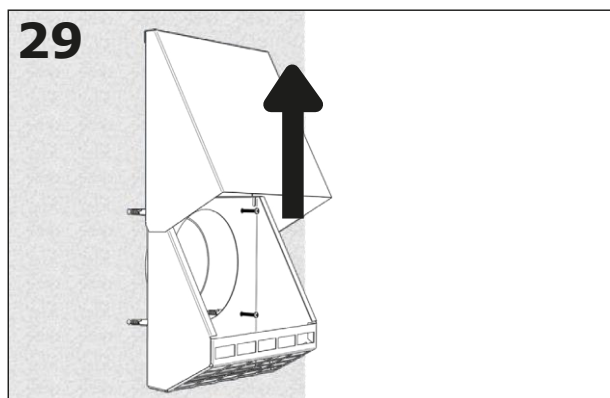
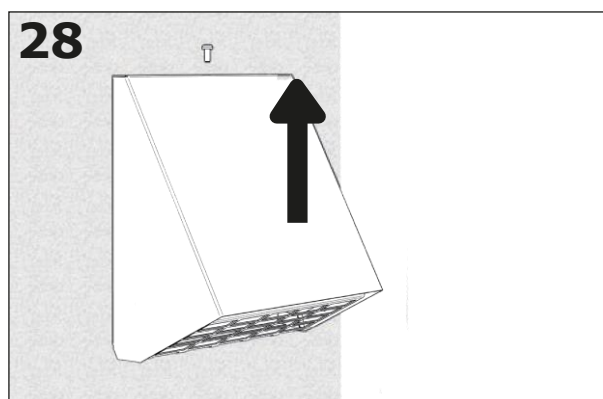
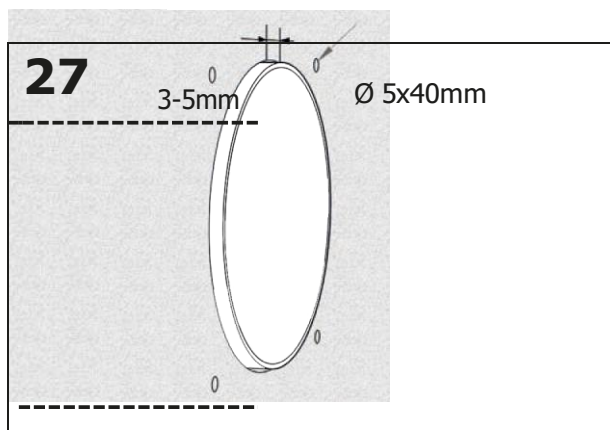
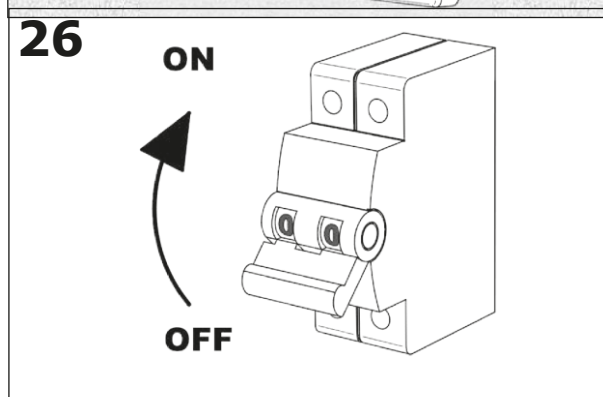
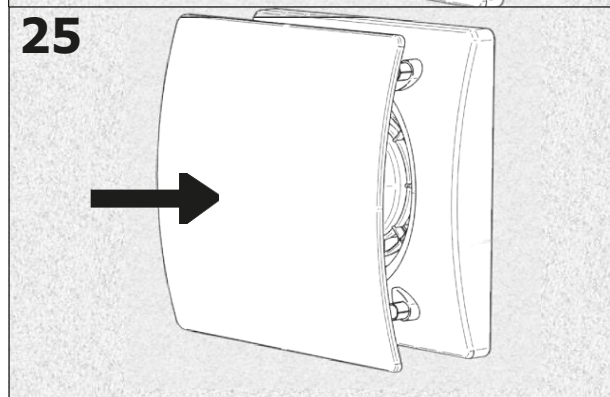
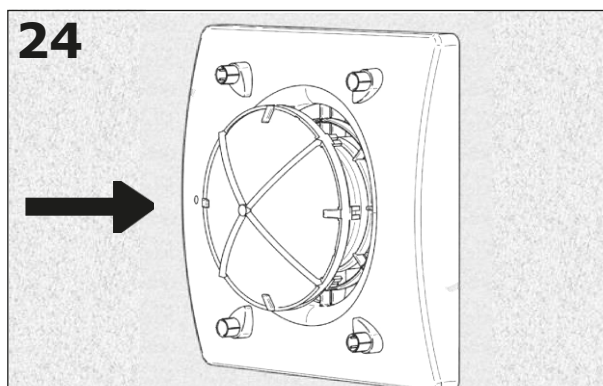
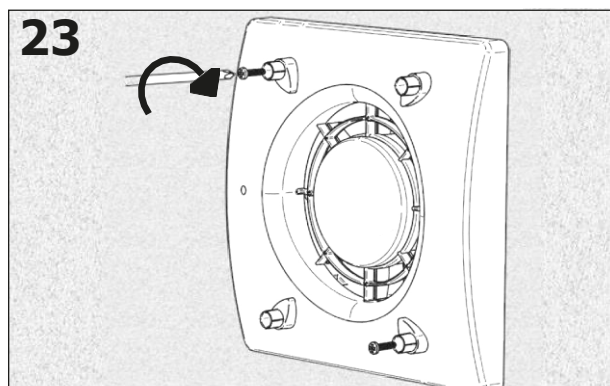

Instrukcja obsługi

WTW-WAND-WI

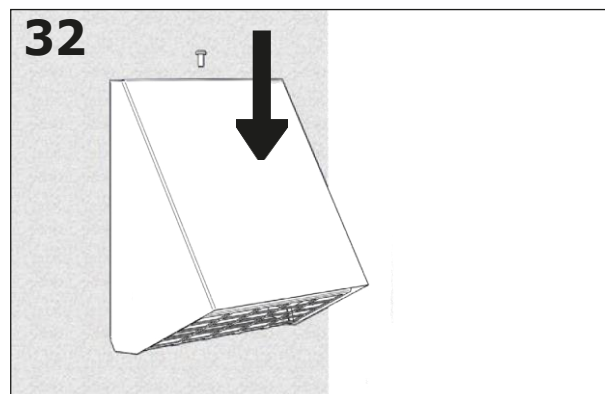
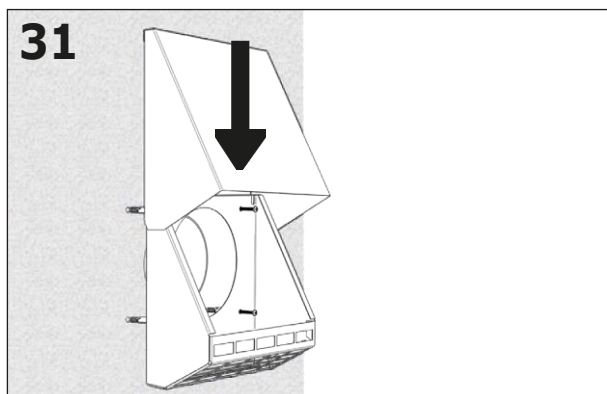

10. Ponowne ustawienie synchronizacji / Reset of the synchronization

OPCJA 1/ OPTION 1

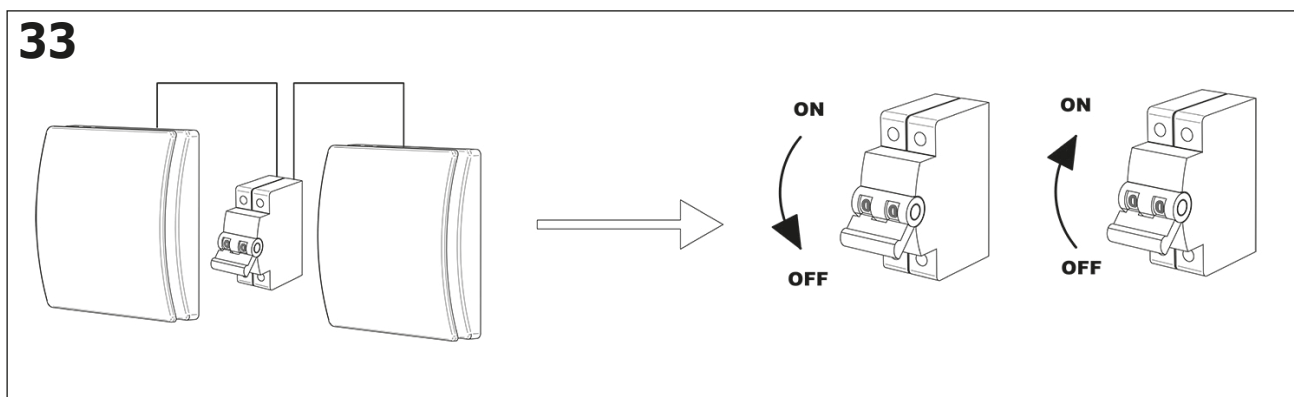

OPCJA 2/ OPTION 2

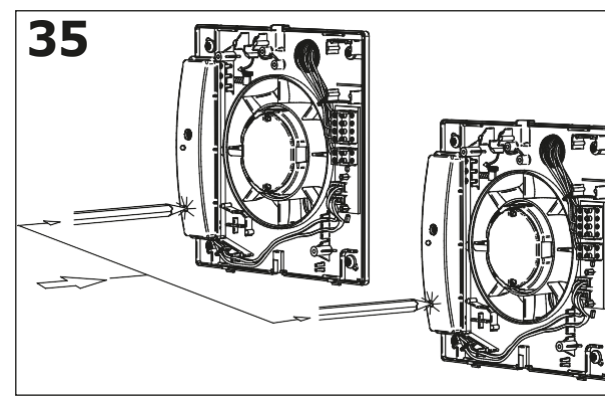
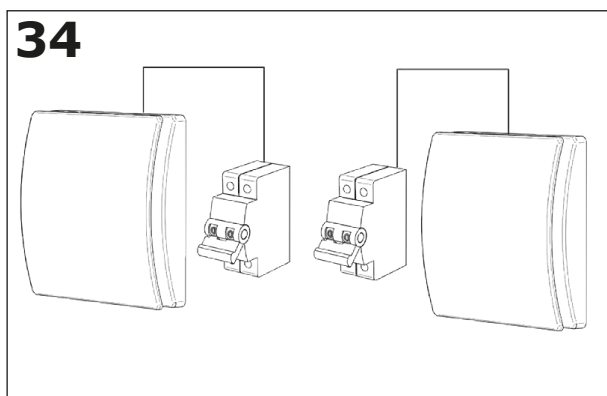

Instrukcja obsługi

WTW-WAND-WI

11. Czyszczenie filtra (konserwacja) / Filter cleaning (maintenance)



UWAGA! NOTE!

Czyszczenie filtra może być wykonane przez użytkownika.
 Filter cleaning can be carried out by the user.

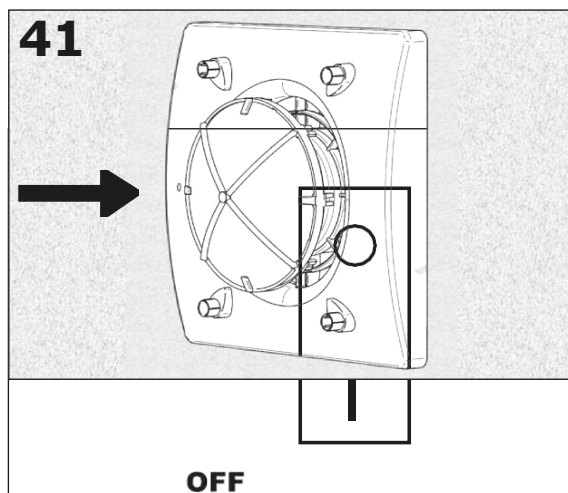
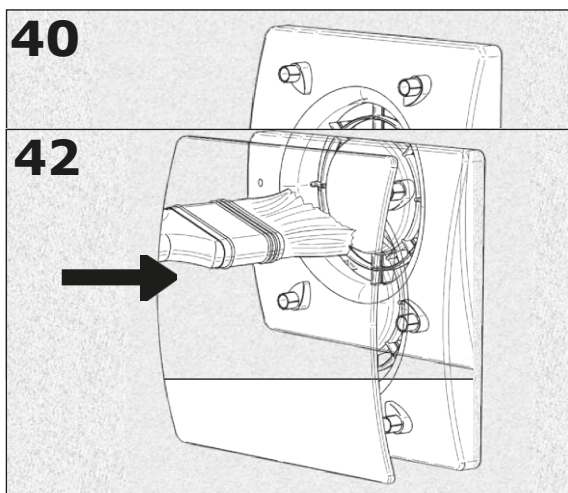
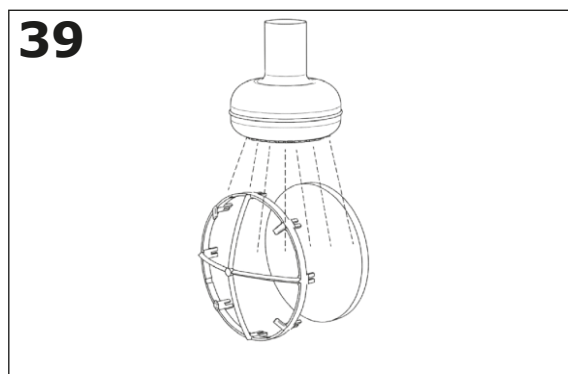
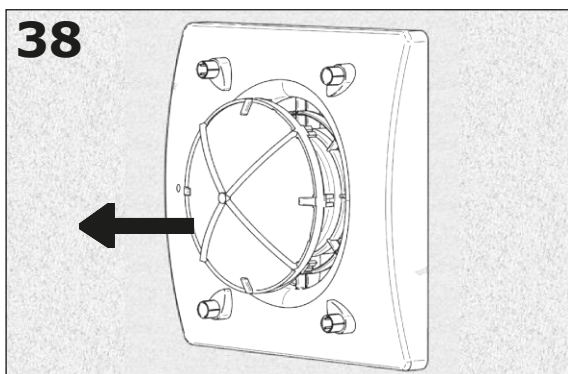
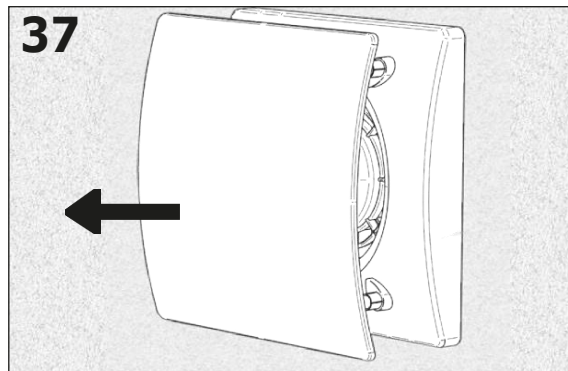
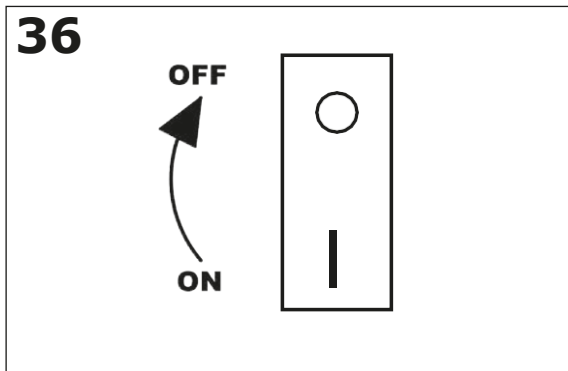

OFF



ON

Instrukcja obsługi

WTW-WAND-WI

12. Czyszczenie wymiennika (serwis)/ Heat exchanger cleaning (service)



UWAGA! NOTE!

Czyszczenie wymiennika musi zostać wykonane przez uprawnionego instalatora.
Heat exchanger cleaning must be carried out only by technically qualified personnel.

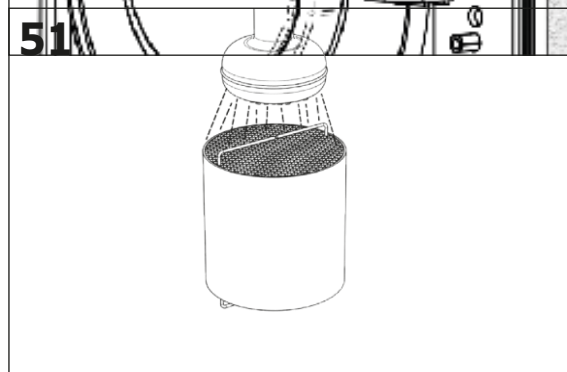
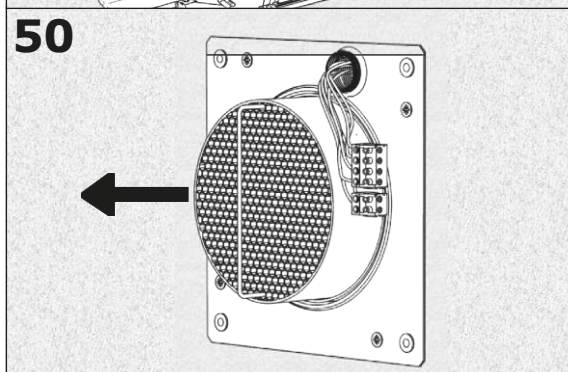
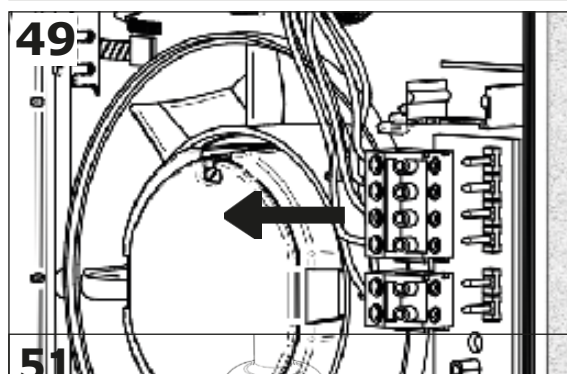
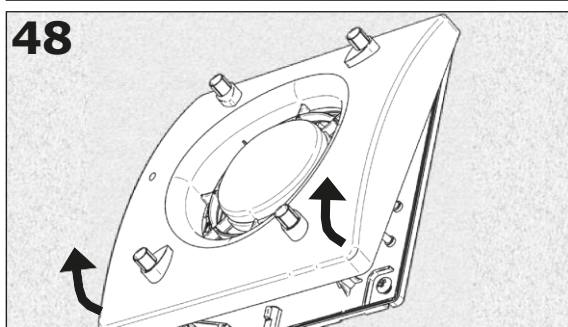
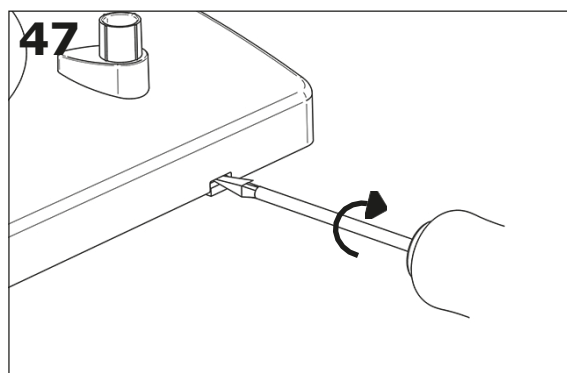
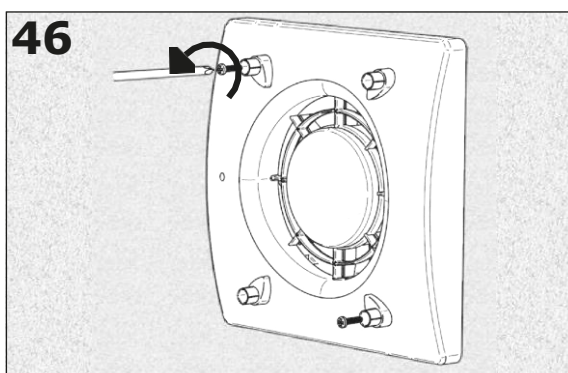
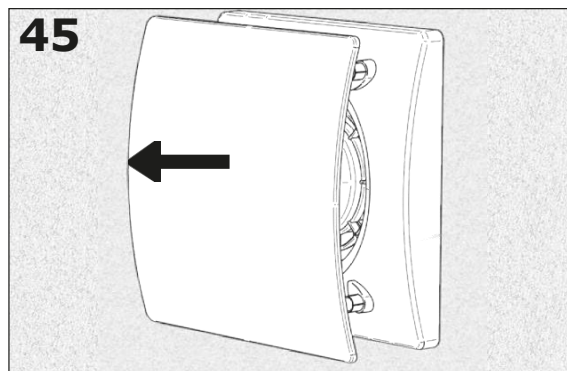
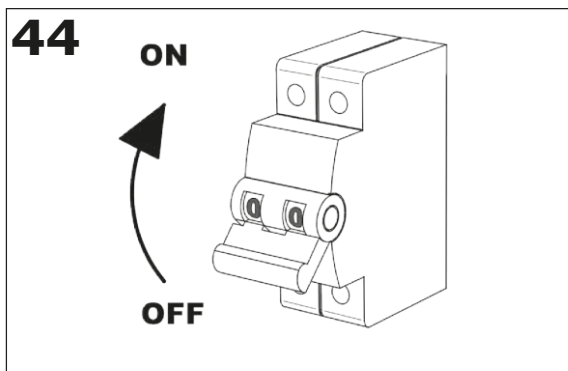

Instructie obsługi

WTW-WAND-WI

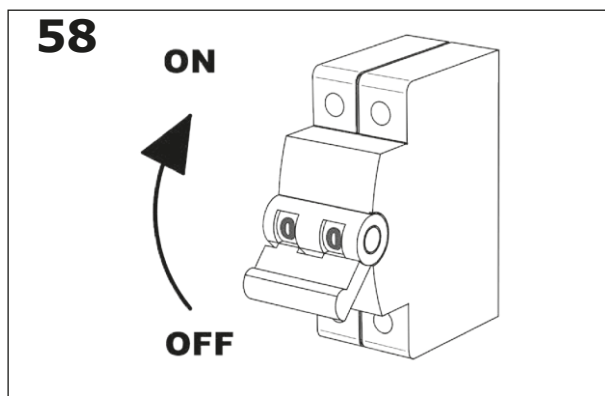
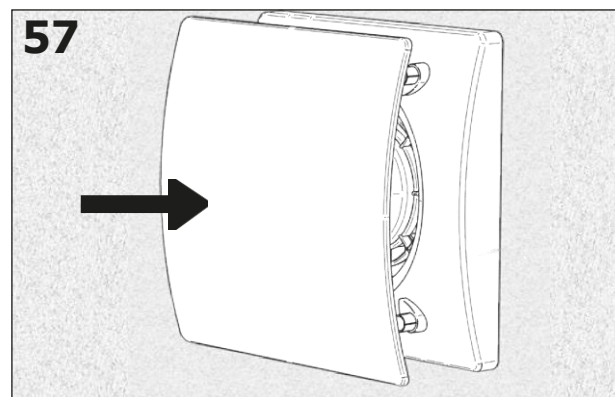
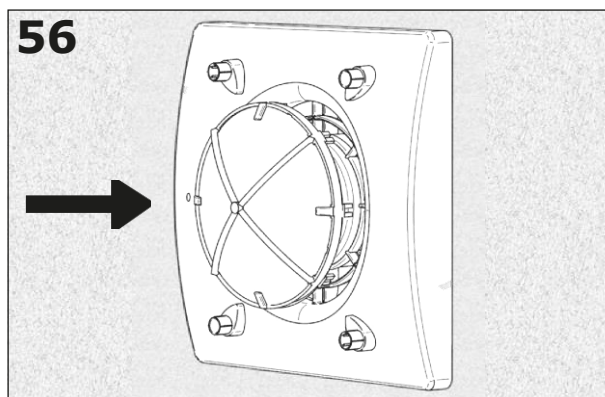
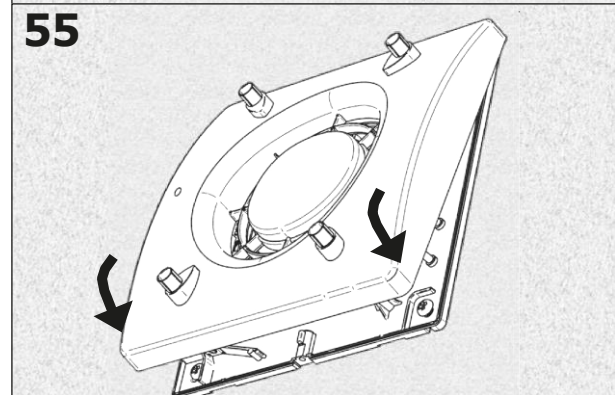
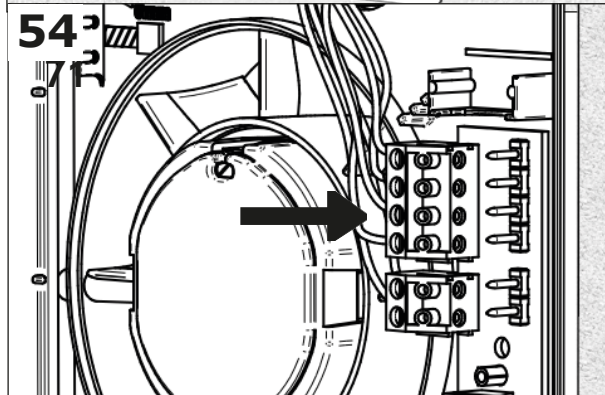
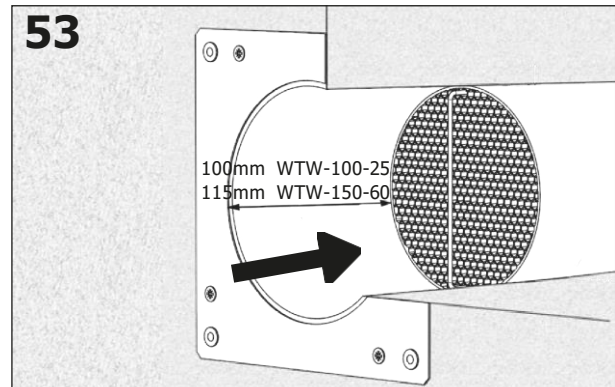
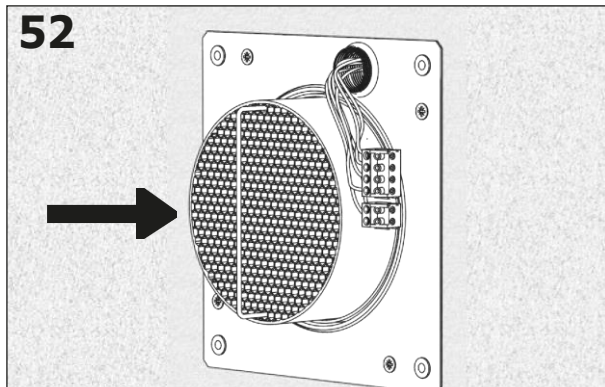

Instrukcja obsługi

WTW-WAND-WI

13. Etykieta energetyczna / Energy Label

Model	Poziom mocy akustyczne L_{wa} Sound power level L_{wa} [dB]	Wydajność Airflow [m ³ /h]	Klasa energetyczna Energy class
WTW-WAND-WI-150-60	38	60	A

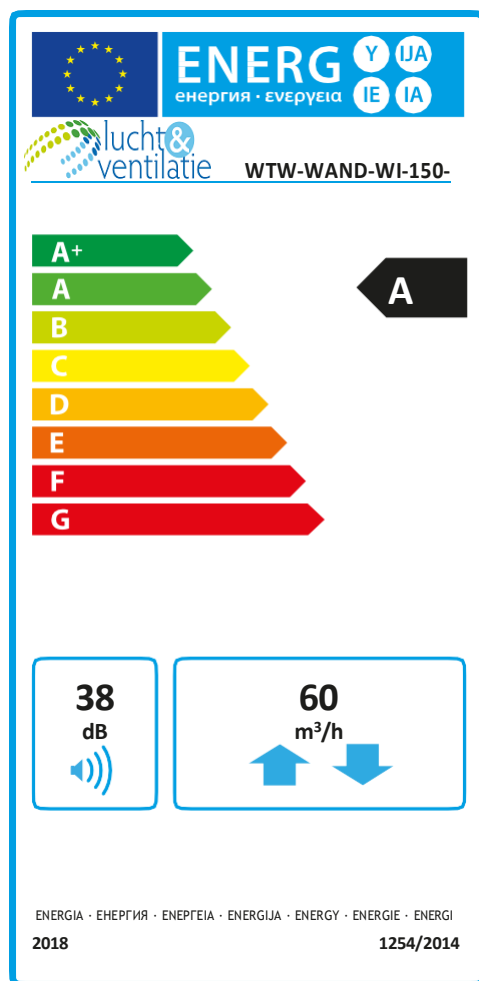

Instrukcja obsługi

WTW-WAND-WI

14. Karta produktuzgodnactzw. Dyrektywą ERP, Rozporządzenia 1253/2014, 1254/2014

Nazwa dostawcy lub znak towarowy	LUCHT & VENTILATIE					
Identyfikator modelu	WTW-WAND-100-25			WTW-WAND-150-60		
Jednostkowe zużycie energii (JZE) [kWh/(m ² /rok)] (ciepły, umiarkowany, chłodny)	-15,6	-37,5	-75,6	-16,2	-38,2	-76,4
Klasa energetyczna	A					
Typ jednostki	Mieszkalny - dwukierunkowy					
Rodzaj napędu	napęd wielobiegowy					
Rodzaj układu odzysku ciepła	odzysku ciepła					
Przy maksymalnej wydajności	82%					
przy 70% maksymalnego natężenia przepływu zgodnie z Rozporządzeniem 1253/2014 i 1254/2014	74%					
Maksymalna wartość natężenia przepływu	25 m ³ /h			60 m ³ /h		
Pobór mocy przy maksymalnym natężeniu przepływu	2,6 W			3,8 W		
Poziom mocy akustycznej (L _{WA})	35 dBA			38 dBA		
Wartość odniesienia natężenia przepływu	17 m ³ /h			41 m ³ /h		
Wartość odniesienia różnicy ciśnienia	10 Pa					
Jednostkowy pobór mocy	0,071 W/m ³ /h			0,054 W/m ³ /h		
Czynnik rodzaju sterowania	1			1		
Typ sterowania	Sterowanie ręczne (brak sterowania według zapotrzebowania)					
Współczynnik maksymalnych wewnętrznych przecieków powietrza	N/A					
Współczynnik maksymalnych zewnętrznych przecieków powietrza	1					
Współczynnik mieszania wewnętrznego	N/A					
Współczynnik mieszania zewnętrznego -	N/A					
Ostrzeżenia o konieczności wymiany filtra	N/A					
Instrukcja instalowania kratak	N/A					
Podatność przepływu powietrza na zmiany ciśnienia	N/A					
Szczelność między wnętrzem i obszarem na zewnątrz budynku	21 m ³ /h			60 m ³ /h		
Roczne zużycie energii elektrycznej [kWh/rok] (ciepły, umiarkowany, chłodny)	1	1	1	0,7	0,7	0,7
Roczne oszczędności w ogrzewaniu (ROO) [kWh/rok] (ciepły, umiarkowany, chłodny)	18	39,9	78	18,1	40	78,2

Instructie obsługi

WTW-WAND-WI

14. Product fiche according to ERP Directive, Regulations 1253/2014, 1254/2014

Mark	LUCHT & VENTILATIE					
Model	WTW-WAND-100-25			WTW-WAND-150-60		
Specific energy consumption (SEC) [kWh/(m ² /rok)] (warm, average, cold climates)	-15,6	-37,5	-75,6	-16,2	-38,2	-76,4
Energy class	A					
Unit typology	Residential - bidirectional					
Type of drive	multi-speed drive					
Type of Heat Recovery System	heat recovery					
Maximum thermal efficiency	82%					
at 70% at least of the maximum flow rate to the Regulation 1253/2014 and 1254/2014	74%					
Maximum flow rate	25 m ³ /h			60 m ³ /h		
Electric power input at maximum flow rate	2,6 W			3,8 W		
Sound power level (L _{WA})	35 dBA			38 dBA		
Reference flow rate	17 m ³ /h			41 m ³ /h		
Reference pressure difference	10 Pa					
Specific power input (SPI)	0,071 W/m ³ /h			0,054 W/m ³ /h		
Control factor	1			1		
Control typology	Manual control (no DCV)					
Maximum internal leakage rate	N/A					
Maximum external leakage rate	1					
Internal mixing rate	N/A					
External mixing rate	N/A					
Visual filter warning	N/A					
Instructions to install regulated grilles	N/A					
Airflow sensitivity to pressure variations	N/A					
Indoor/outdoor air tightness	21 m ³ /h			60 m ³ /h		
Annual electricity consumption (AEC) [kWh/year] (warm, average, cold climates)	1	1	1	0.7	0.7	0.7
Annual heating saved (AHS) [kWh/year] ((warm, average, cold climates)	18	39.9	78	18.1	40	78.2